



## VDP-U-MPM200170-01

This hydraulic power unit is mainly used in mini excavator and electric forklift truck. This product adopts the combination of high-power permanent magnet synchronous motor and large displacement internal meshing gear pump, low energy consumption, low noise, low speed and high pressure.

### Technical Attributes

Model Code	VDP-U-MPM200170-01
Motor Voltage	200V
Motor Power	17KW
Rated Speed	2079rpm
Pump Capacity	20mL/r
Oil Port	Inlet: $\phi 19$ /outlet: $\phi 13$



### Outline Dimensions

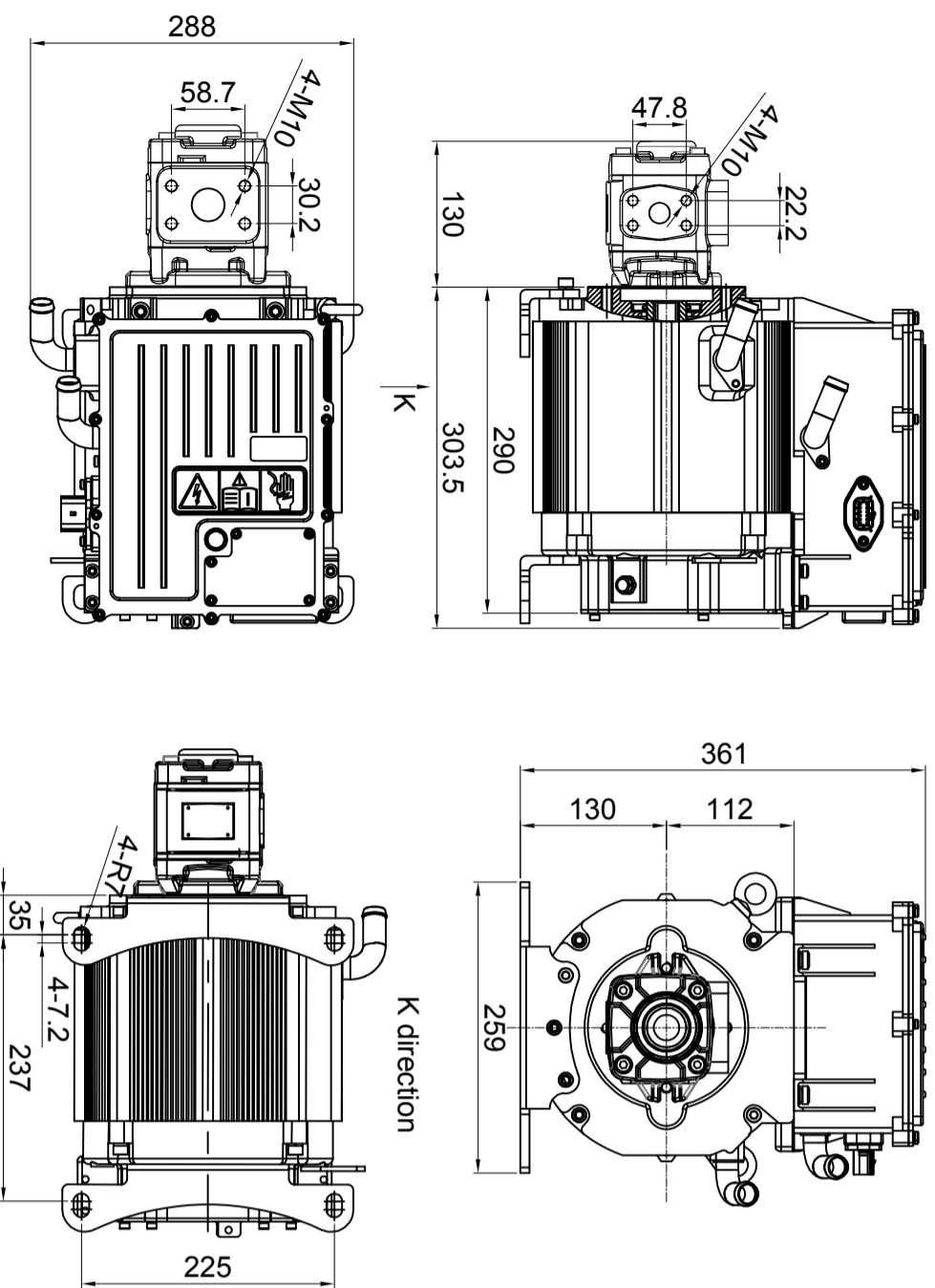

### Hydraulic Schematic Diagram

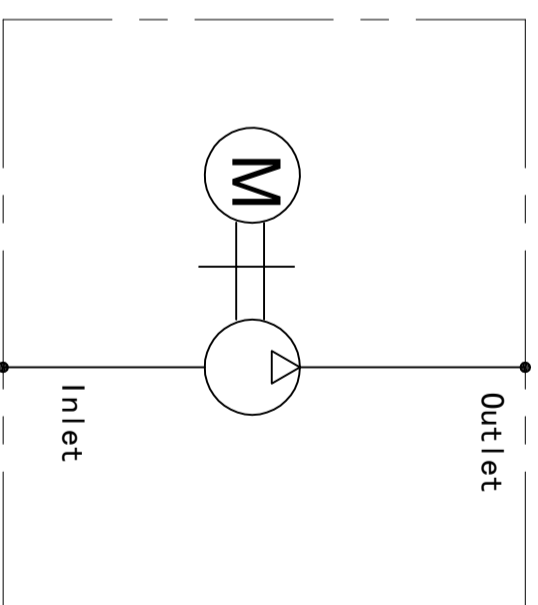

### Characteristic curve

