



VDP-U-MD24220-17-T

This product provides lifting and lowering function for Tail Gate, power lifting, self weight descending, equipped with two-way check solenoid valve, good pressure keeping performance, equipped with throttle valve, the speed of descent is adjustable and the descent is smooth. Solenoid valve and check valve are with manual function, in the absence of electricity with emergency descent function.

Technical Attributes

Model Code	VDP-U-MD24220-17-T
Motor Voltage	24V
Motor Power	2.2kW
Rated Speed	2800rpm
Pump Capacity	3.3mL/r
System Pressure	12MPa
Tank Capacity	12L
Oil Port	G1/4"

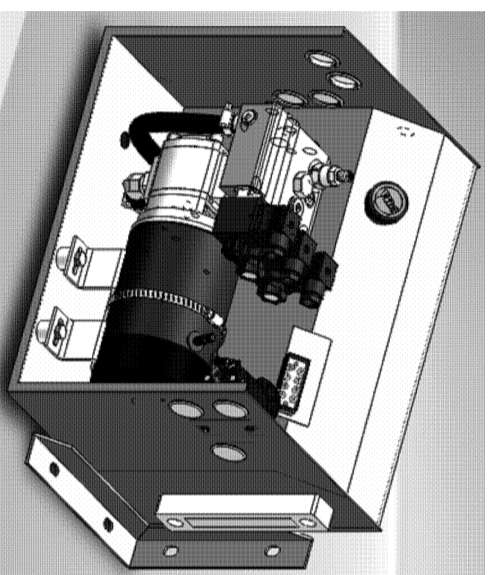

Outline Dimensions

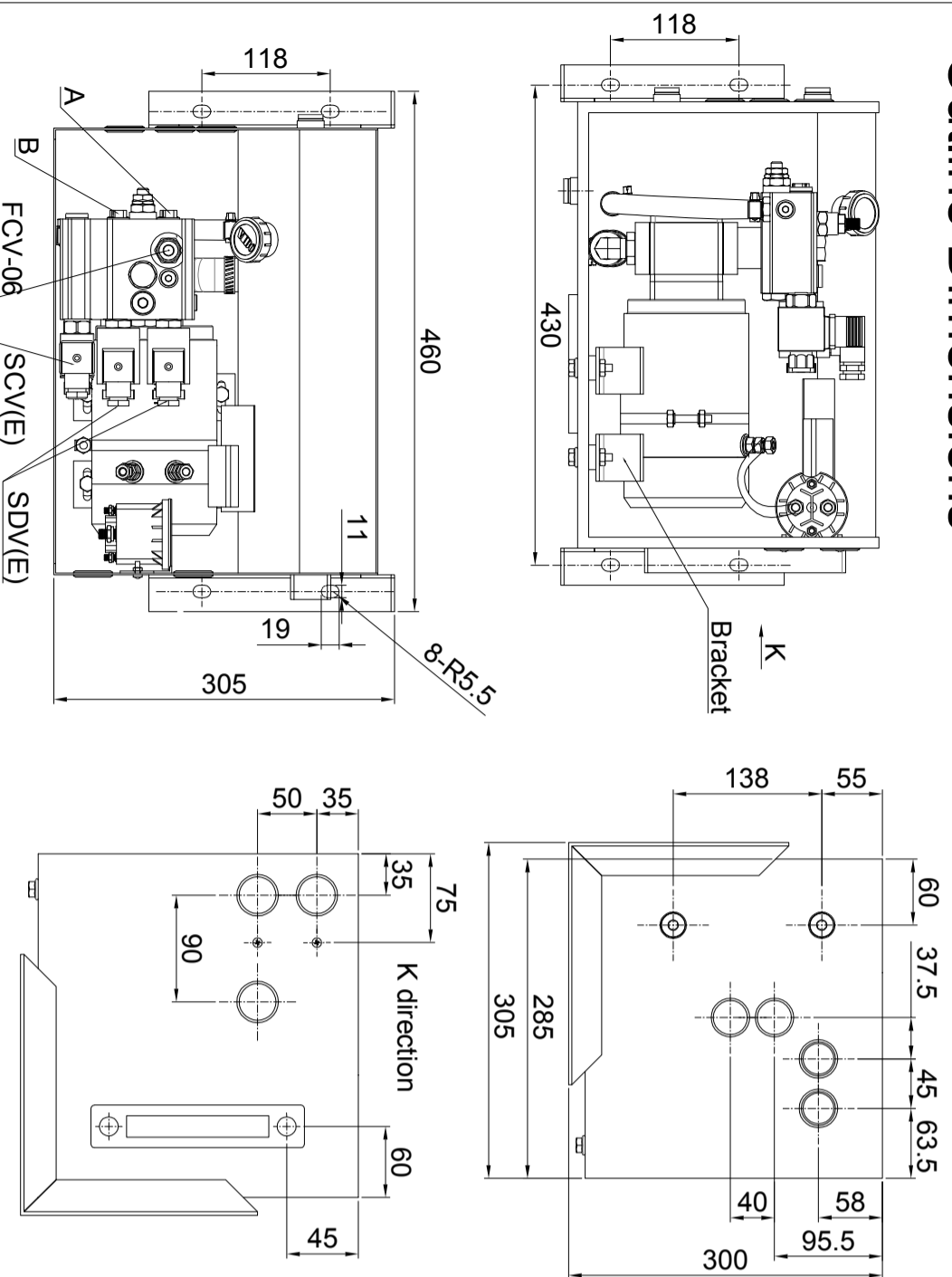

Hydraulic Schematic Diagram

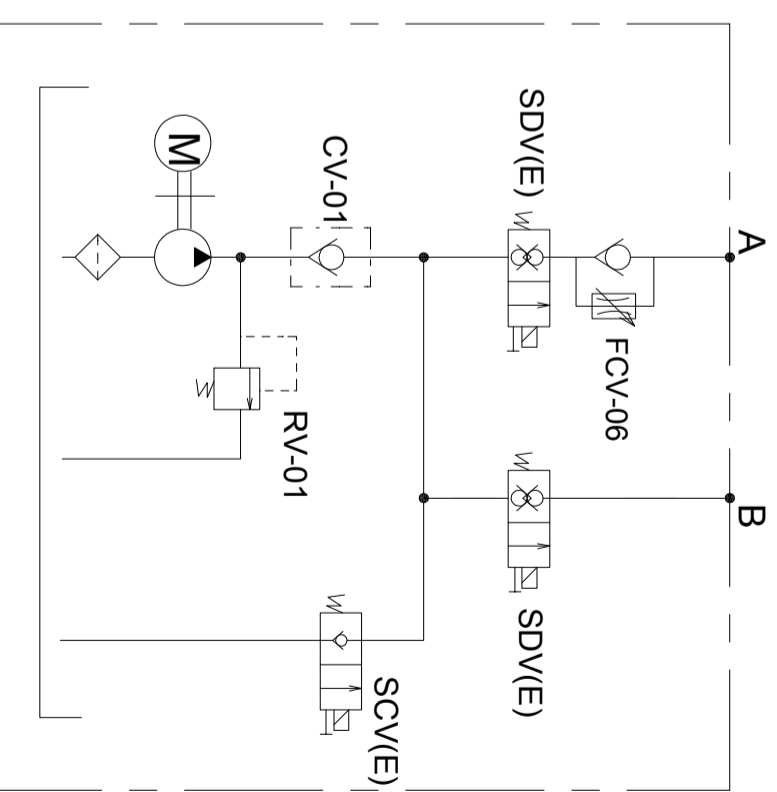

Characteristic curve

