



VDP-U-MD24080AN-21-P

The product mainly provides lifting function for AGV, equipped with self-developed 24V 0.8kW high performance DC motor, 0.8L plastic tank, CBU gear pump, quantitative pressure compensating throttle valve, smooth ascending and descending. While satisfying the lifting function, the size of the power unit is minimized, which is especially suitable for product like AGV that require the size of parts.

Technical Attributes

Model Code	VDP-U-MD24080AN-21A-P
Motor Voltage	24V
Motor Power	0.8kW
Rated Speed	3400rpm
Pump Capacity	0.38mL/r
System Pressure	18MPa
Tank Capacity	0.8L
Oil Port	M14*1.5

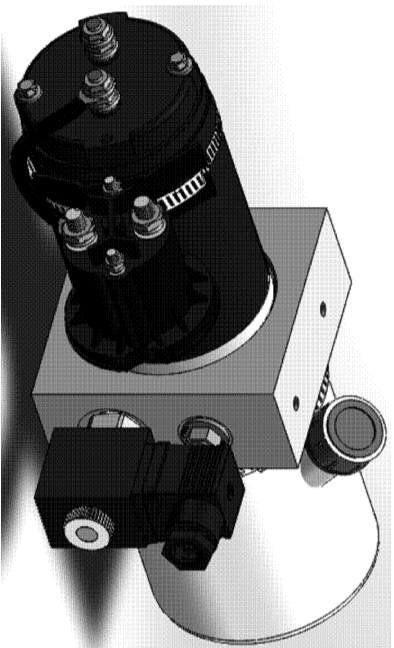

Outline Dimensions

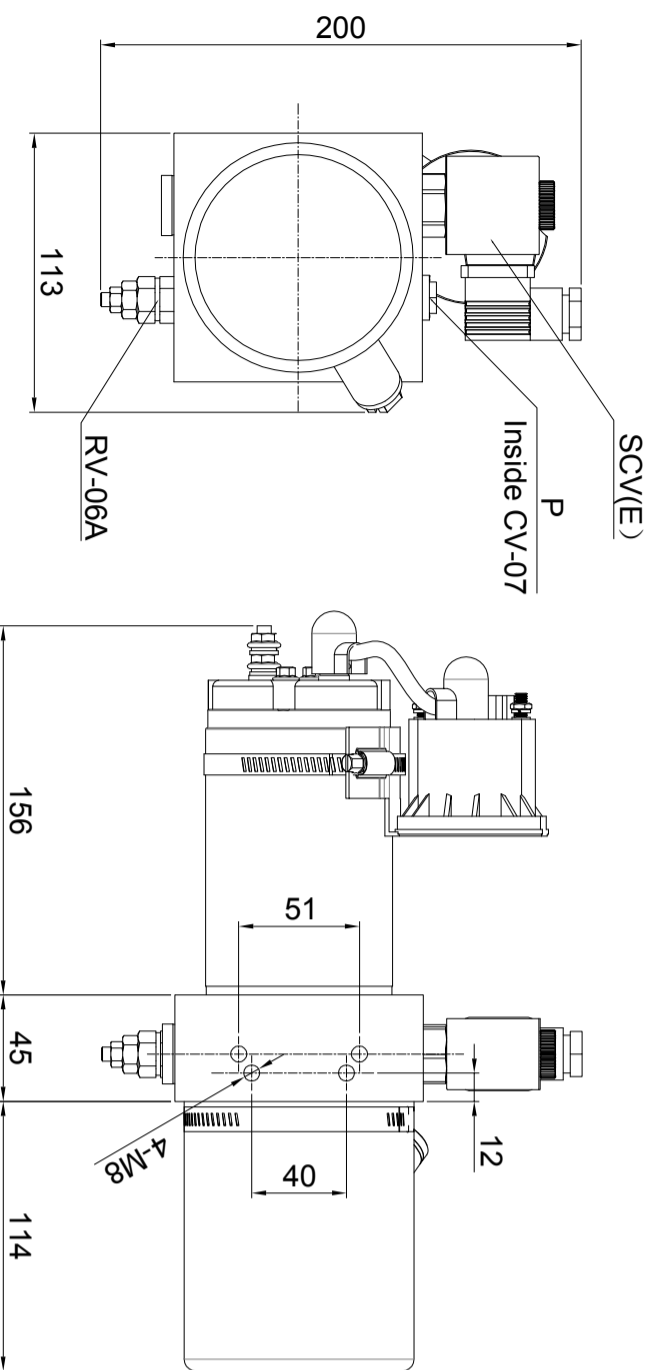

Hydraulic Schematic Diagram

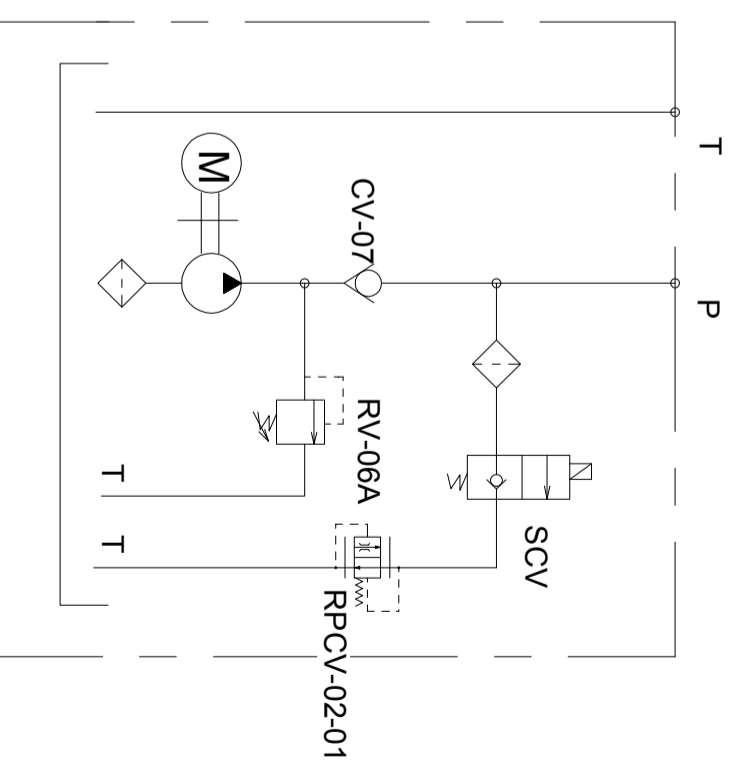

Characteristic curve

