



VDP-U-MD12200-18-T

This unit provides lifting and lowering function for trailers, built-in the self-researched & developed quantitative pressure compensation throttle valve, lowering smoothly, wire control button switch is optional. This power unit integrates DC motor, helical gear pump, hydraulic valve set and hydraulic oil tank in one. Hydraulic system with low noise, easy to install and use.

Technical Attributes

Model Code	VDP-U-MD12200-18-T
Motor Voltage	12V
Motor Power	2.0KW
Rated Speed	2586rpm
Pump Capacity	2.0mL/r
System Pressure	22MPa
Tank Capacity	6L
Oil Port	9/16-18UNF



Outline Dimensions

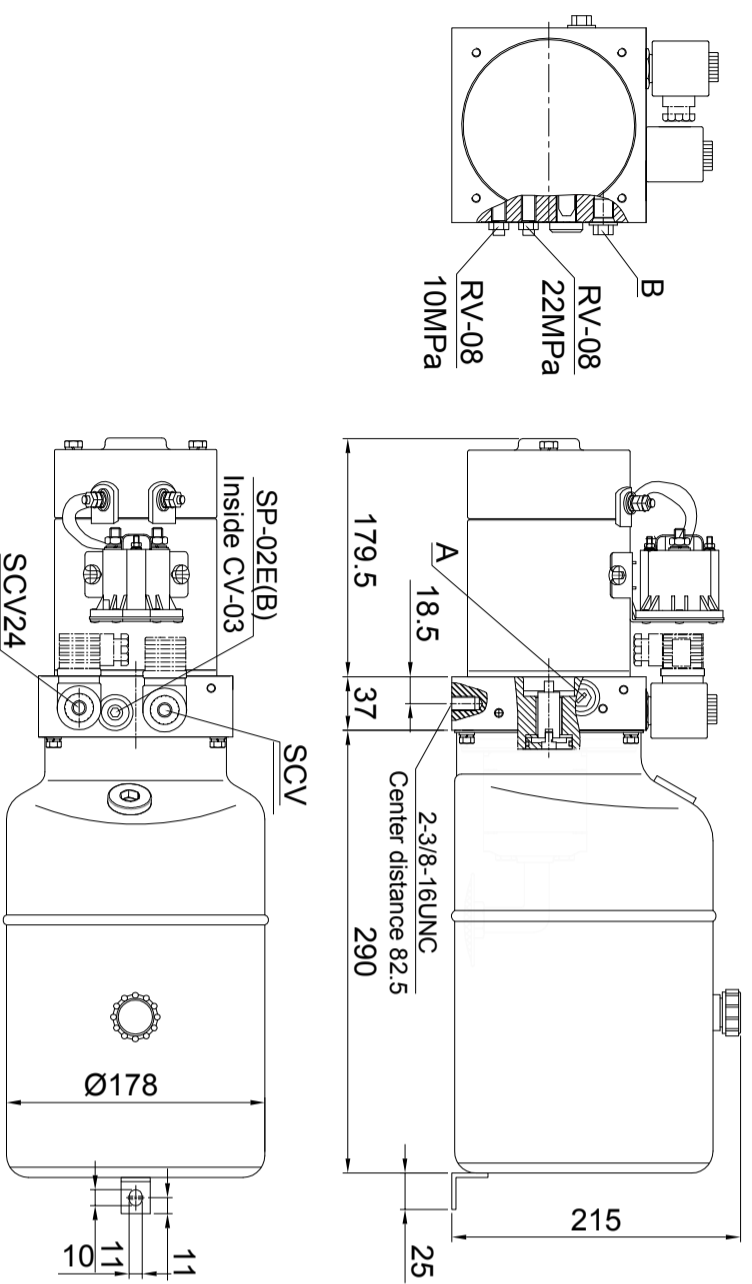

Hydraulic Schematic Diagram

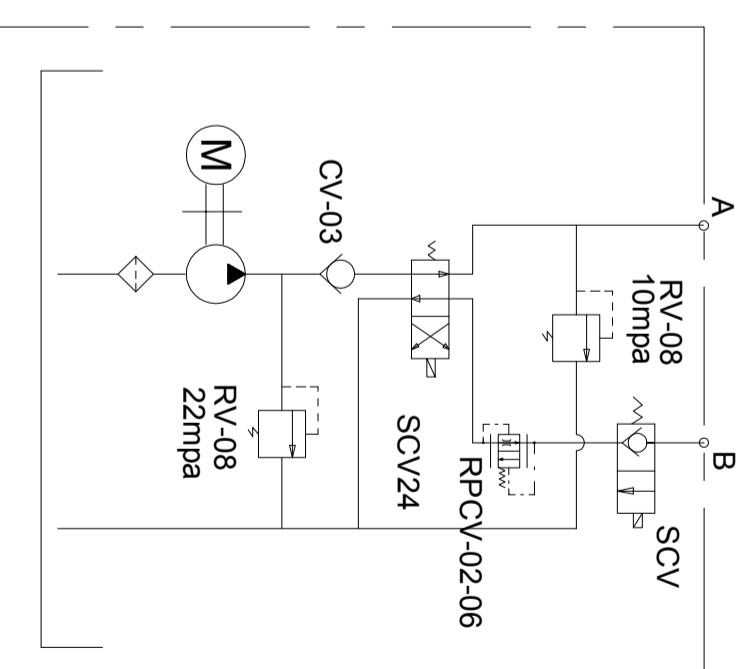

Characteristic curve

