

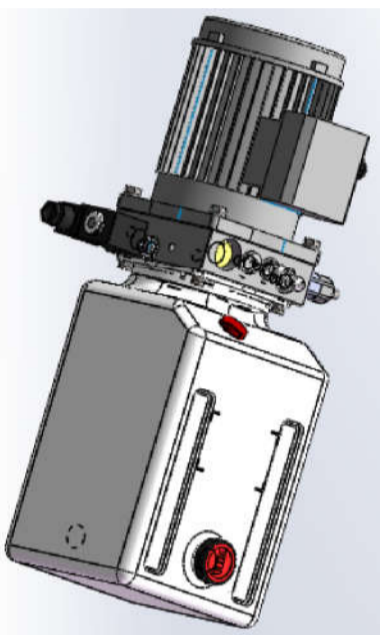

VAPU-MS230/400075-2-19-P

Technical Attributes

Model Code	VAPU-MS230/400075-2-19-P
Motor Voltage	230/400V
Motor Power	0.75kW
Rated Speed	2850rpm
Pump Capacity	1.6mL/r
System Pressure	12MPa
Tank Capacity	6L
Oil Port	G1/4"



Outline Dimensions

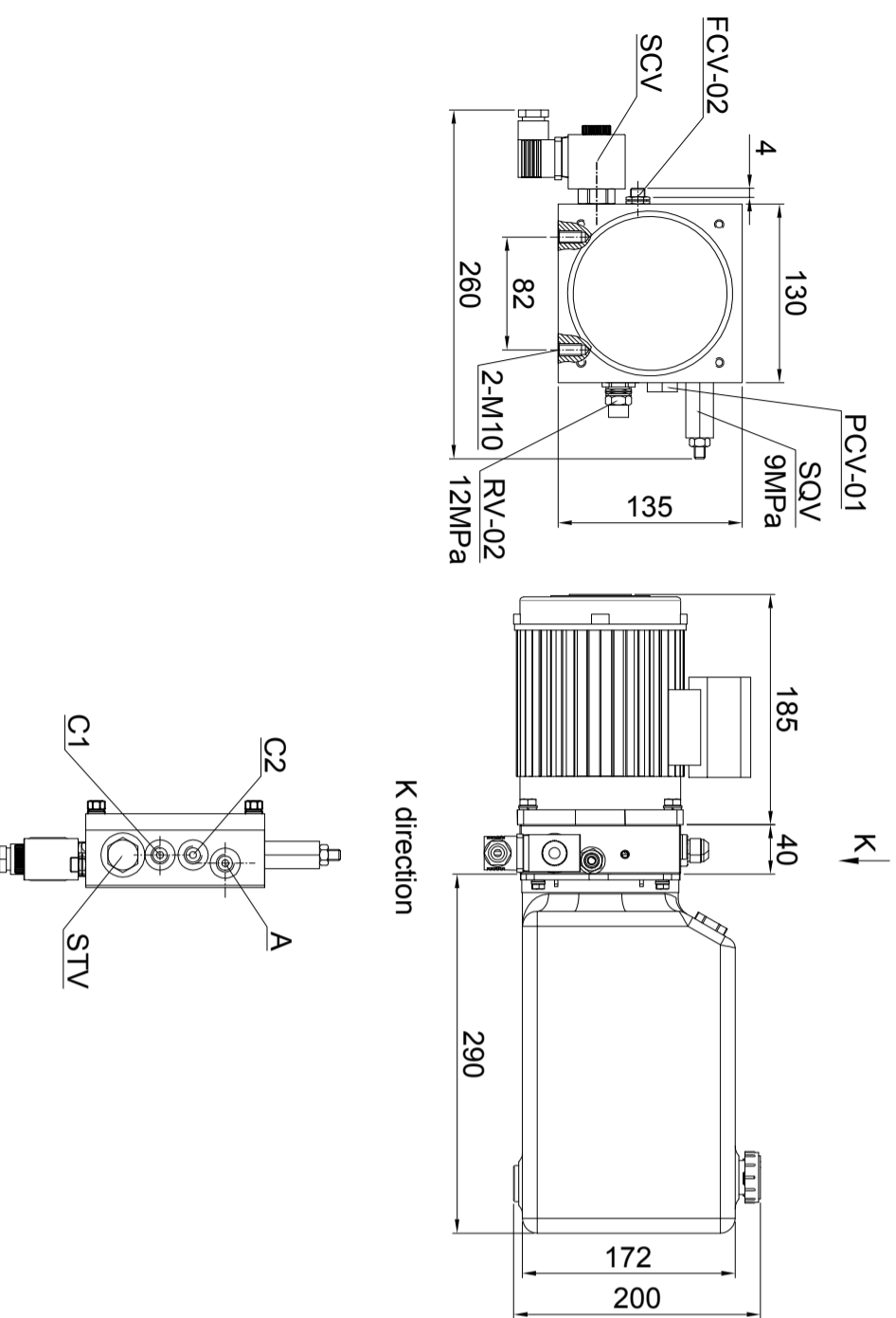

Hydraulic Schematic Diagram

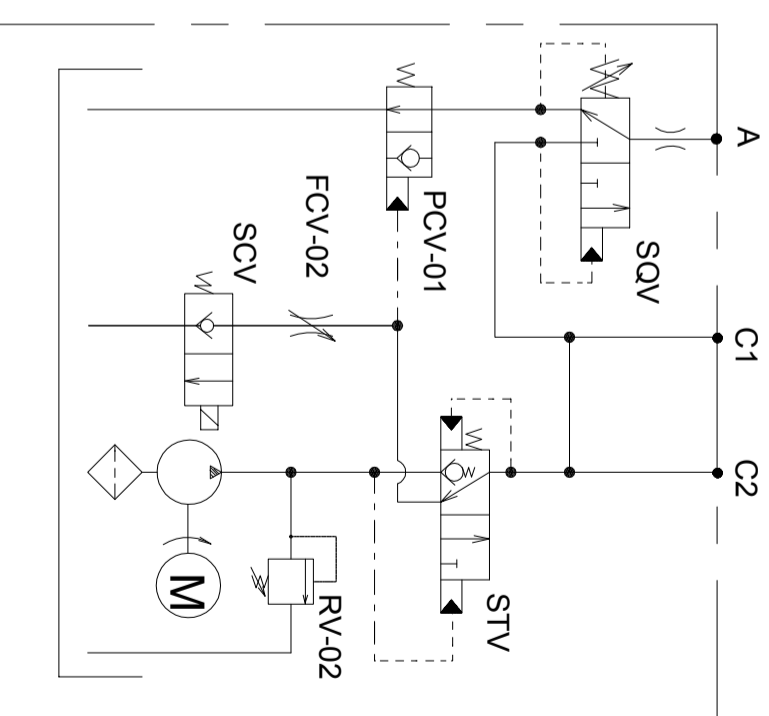

Characteristic curve

